

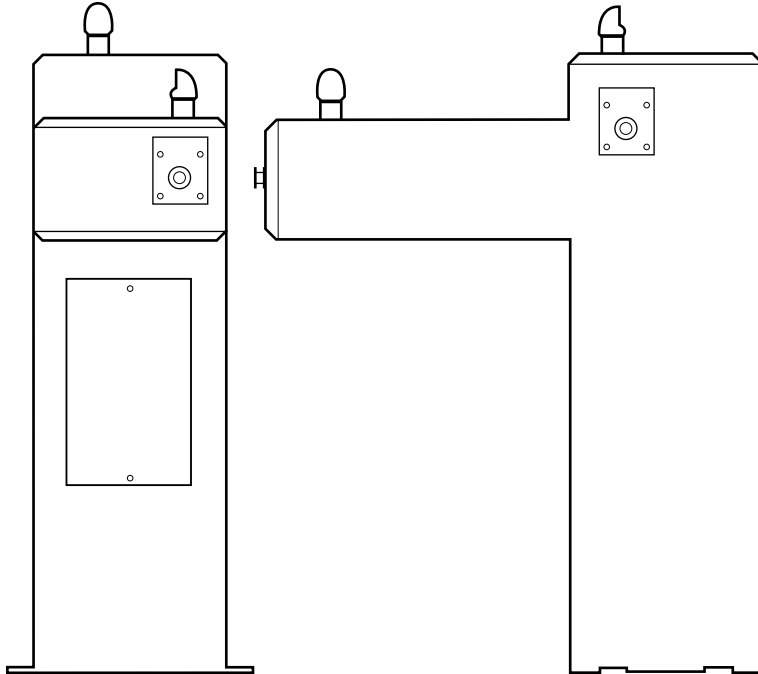

BOHLMANN™
QUALITY PRODUCTS



STOP!

PLEASE READ THE FOLLOWING INFORMATION.

INSTALLER

DF-DUAL-FR Fountains are among the easiest to install Fountains on the market today. To assure you install these models easily and correctly, **PLEASE READ THESE SIMPLE INSTRUCTIONS BEFORE STARTING THE INSTALLATION.** CHECK YOUR INSTALLATION FOR COMPLIANCE WITH PLUMBING, ELECTRICAL, AND OTHER APPLICABLE CODES.

After installation, leave these instructions with the Fountain for future reference.

This Freeze Resistant Fountain is shipped in two separate cartons. The second carton contains the Freeze Resistant Package that is installed on an interior heated wall. Refer to the Freeze Resistant Package for the rough-in dimensions for installation.

IMPORTANT

ALL SERVICE TO BE PERFORMED BY AN AUTHORIZED SERVICE PERSON

IMPORTANT

THE GROUNDING OF ELECTRICAL EQUIPMENT SUCH AS TELEPHONE, COMPUTERS, ETC. TO WATER LINES IS A COMMON PROCEDURE. THIS GROUNDING MAY BE IN THE BUILDING OR MAY OCCUR AWAY FROM THE BUILDING. THIS GROUNDING CAN CAUSE ELECTRICAL FEEDBACK INTO A FOUNTAIN, CREATING AN ELECTROLYSIS WHICH CAUSES A METALLIC TASTE OR AN INCREASE IN THE METAL CONTENT OF THE WATER. THIS CONDITION IS AVOIDABLE BY USING THE PROPER MATERIALS AS INDICATED. ANY DRAIN FITTINGS PROVIDED BY THE INSTALLER SHOULD BE MADE OF PLASTIC TO ELECTRICALLY ISOLATE THE FOUNTAIN FROM THE BUILDING PLUMBING SYSTEM

DF-DUAL-FR

Freeze Resistant
Pedestal Barrier Free Stone Fountain

Owner's Manual

2302 Yellow Smoke Road
PO Box 369
Denison, IA 51442
800.325.2380
www.bohlmann.com

IMPORTANT! INSTALLER PLEASE NOTE

Do not pull up on lines coming out of the PVC column. This raises the water valve above the frost line with disastrous results.

GENERAL INSTALL TIPS

- 1 Be sure to flush water supply line before you connect it to the inlet fitting on Freeze Resistant Valve System.
- 2 There are two drain lines required for this unit. One for the drinking fountain basin drain and one for the valve/water supply line system. The bowl drain is the 3/4" PVC fitting at the bottom of the 6" PVC tube and the valve drains through the small holes in the PVC cap. Provide ample drainage for these two items. It's always better to have too much than not enough.
- 3 The column (6" PVC tube) must remain vertical. Be sure it remains vertical when backfilling the excavating trench.
- 4 When the concrete pad, for mounting the fountain, is poured, be sure to allow adequate space around the top of the column so that the flexible cap may be removed for servicing the valve.
- 5 We recommend that the top of the column be flush or slightly above the top height of the concrete pad.
- 6 You should test the unit before you backfill. Simply blow on the clear, small diameter tubing. A steady stream should flow from the braided tubing line. When air pressure is removed from the clear tubing the water stream should stop.
- 7 Once you have tested the valve, backfilled the hole and poured the concrete mounting pad you are ready to set the fountain. After bolting the fountain in place connect the air control valve tubing, supply water tubing and drain lines. The water supply line must have a straight run from the basin bubbler down to the control valve. If a straight run is not maintained water will become trapped and freeze leaving the unit inoperable. Test the fountain again. If it fails to work, the air control line may be kinked or connected improperly. Be sure to keep water out of the air control line.
- 8 These products are designed to operate on 20 psig to 105 psig supply line pressure. If inlet pressure above 105 psig, a pressure regulator must be installed in the supply line. Any damage caused by reason of connecting this product to supply line pressure lower than 20 psig or higher than 105 psig is not covered by warranty

LEGEND

- A:** Access Panel
- B:** Removable Bottom Cover
- C:** 1" PVC Drain
- D:** Pressure Fitting 1-1/4" x 3/4"
- E:** Connector 1-1/4" x 1-1/4"
- F:** 1 - 1/4" Drain Tube
- G:** Air Control Line
- H:** 1/4" Water Line

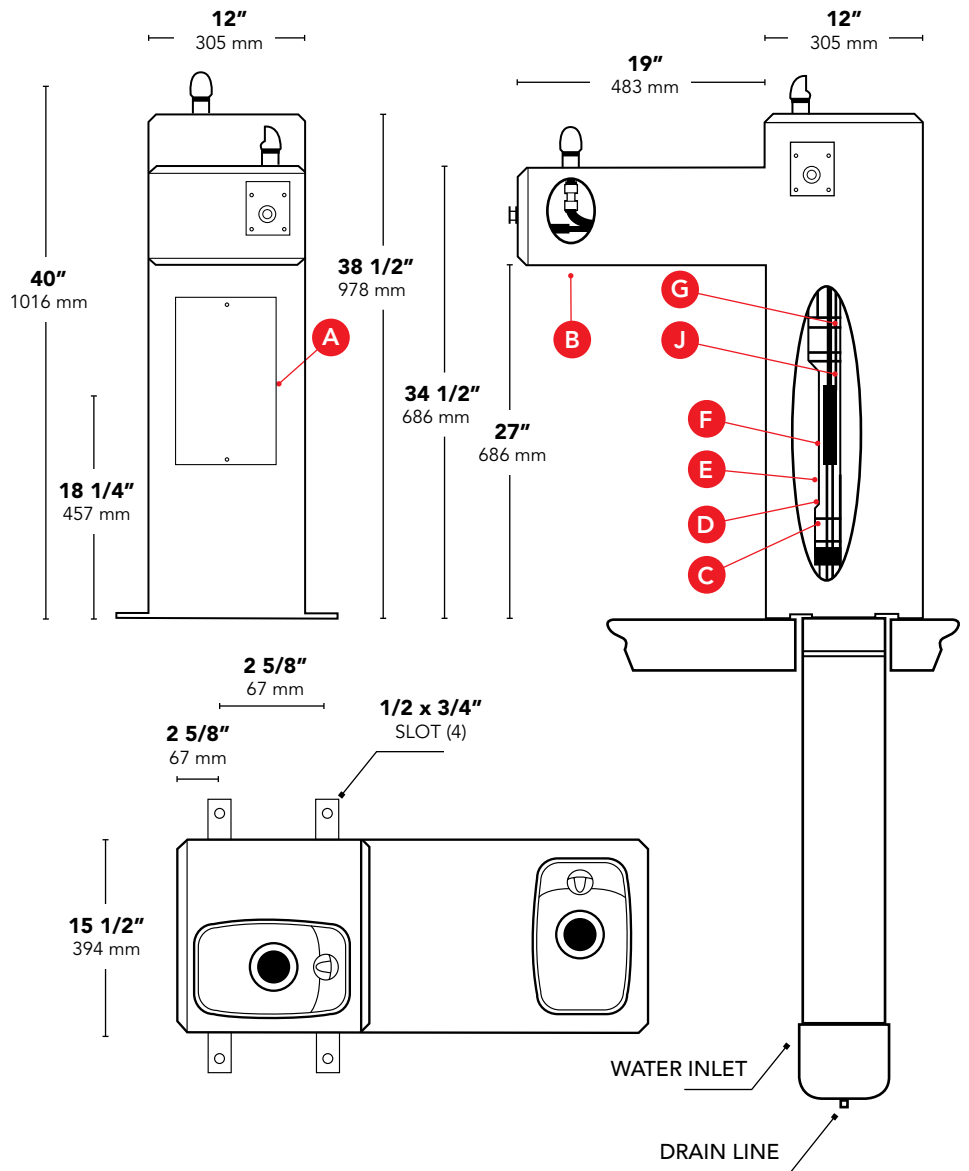

INSTALLATION INSTRUCTIONS FOR INSTALLING 97243C SINGLE VALVE CONTROL ASSY.

- 1 Prepare trench for water supply and waste drain lines (if required by local codes). The hole should be deep enough to accommodate the PVC column and 5 cubic feet of porous fill (large broken rock). Additional porous fill may be required due to local ground conditions.
- 2 Lay drain lines and water supply lines. Provide service shut off valve for maintenance. Flush the water supply line before attaching to the shut off valve.
- 3 Set PVC column in excavating pit. Connect the water supply line to the inlet on the PVC column. Remove valve assembly from the PVC column by carefully pulling up on the connecting tubing. Pressure test the valve assembly for leaks. Check operation of the water valve by blowing on the small clear diameter tubing. A steady stream of water should flow from the braided tubing. After releasing air pressure from the small clear tubing the water stream should stop.
- 4 Replace the water valve into the PVC column. Make sure the supply hose coils into the bottom of the PVC column without any kinks. Cap the PVC column, protect the ends of the connecting tubes and backfill the trench. Keep the PVC column vertical at all times.
- 5 Form the concrete mounting pad and locate the fountain anchor bolts in the proper position. (Refer to Rough-in for correct location of anchor bolts.) Pour concrete and finish. Be sure to keep concrete away from the top of the PVC column to allow removal of PVC cap to allow for future service. Let concrete set 24 hours minimum before mounting fountain.
- 6 Double check that the water valve is positioned fully at the bottom of the PVC column. Install insulation into the PVC column and push down onto the top of the water valve.
- 7 Mount the fountain onto the anchor bolts. Level and shim fountain as required.
- 8 Connect the drain line, water line and air control lines. Excess lengths should be trimmed from the tubing. The water supply line must be positioned for positive drain back out of the fountain and down through the water valve. Any water allowed to be trapped above the frost line will freeze leaving the unit inoperable. Do not pull up on the connection lines as this could raise the valve above the frost line.
- 9 Check for proper operation by using fountain push button. If the valve does not work properly check for leaks or kinks in the air control line.
- 10 After insuring proper operation reassemble fountain. Installation of your fountain is now complete.

TROUBLE SHOOTING

Insufficient Bubbler Flow: Check that the shut-off valve is wide open. Verify minimum 20 PSI supply pressure. Clean inlet strainer screen located in the valve body. Clean rubber orifice in flow control located below frost line in bushing between barb fitting and valve.

No Flow: Check for leaks in the air tubing going from the push button to the valve. Make sure the air tubing compression nut is hand tight. Disconnect air tube from push button. Place finger over air outlet. Push button to test diaphragm. Tighten diaphragm cap screws. Replace diaphragm if necessary.

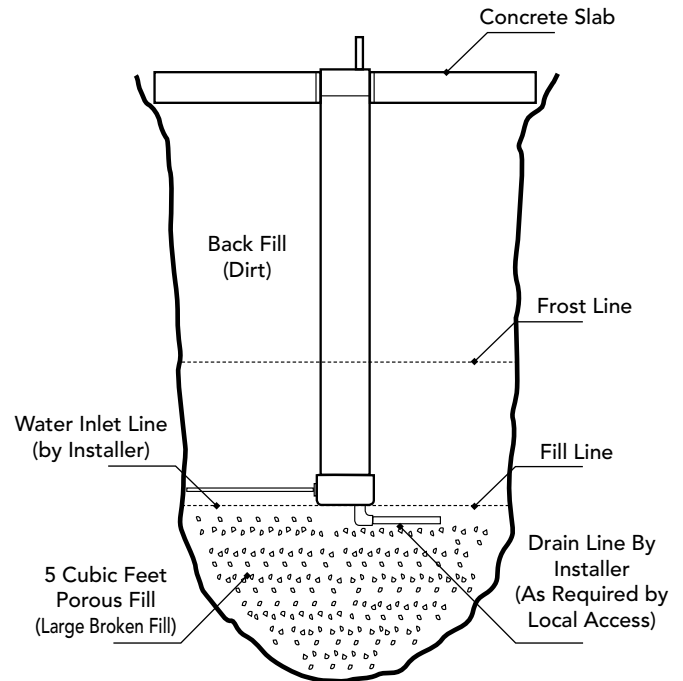

TROUBLE SHOOTING (CONT.)

Continued Insufficient or Varied Height of Bubbler Flow:

- Replace flow control.
- Check for kinks in the tubing.
- Remove the PVC cap from the PVC column. Remove the valve assembly from the PVC column by carefully pulling up on the connecting tubing. Pressure test the valve assembly for leaks. Check stream height from the bubbler. Stream height is factory set at 35 PSI. If supply pressure varies greatly from this, adjust the screw on the regulator (See Parts List, Stream Height Adjustment Detail). Clockwise adjustment will raise stream and counter-clockwise adjustment will lower stream. For best adjustment stream height should be approx. 1-1/2" (38mm) above the bubbler guard. Replace the valve into the PVC column. Make sure the supply hose coils into the bottom of the PVC column without any kinks and double check that the valve is positioned fully at the bottom of the PVC column. Cap the PVC column.

Continuous Bubbler Flow: Insure that push button is not obstructed and springs back to normal position. Remove four screws which secure plastic diaphragm block to valve body. Pull plastic and rubber diaphragm assembly out of valve body. Locate tiny hole in rubber diaphragm just under lip of plastic part. Clean debris from this hole. Inspect valve seat for grooves. If valve seat was OK and diaphragm hole was free from debris, inspect rubber button located at center of floating steel disc in valve diaphragm block assembly. If button is worn, turn disc over or replace it. If diaphragm and seats are in good condition, stretch spring slightly. Spring is located behind floating stainless steel plate. Insure that air bleed port on valve plastic block assembly is not plugged.

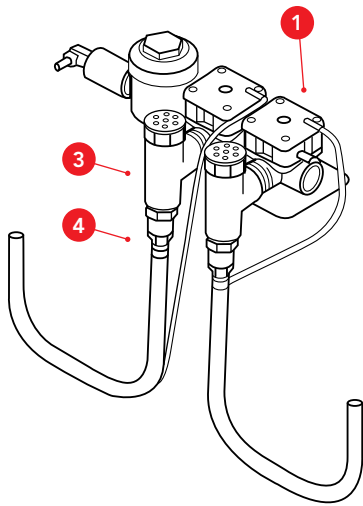

DUAL VALVE ASSY.

2

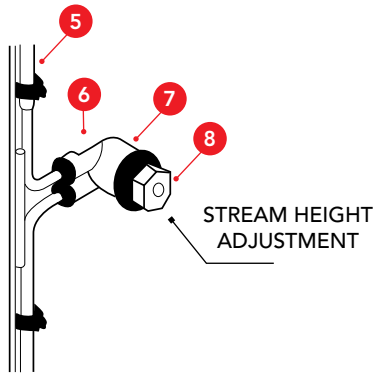

STREAM HEIGHT ADJUSTMENT

STREAM HEIGHT ADJUSTMENT DETAIL

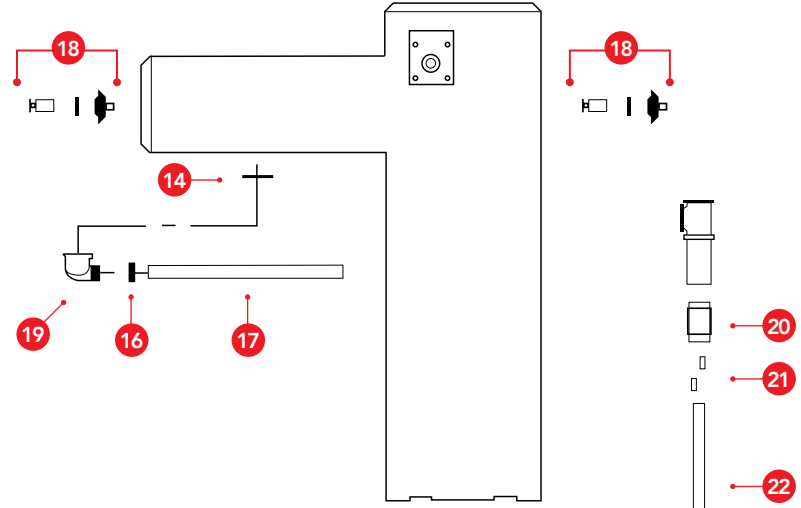
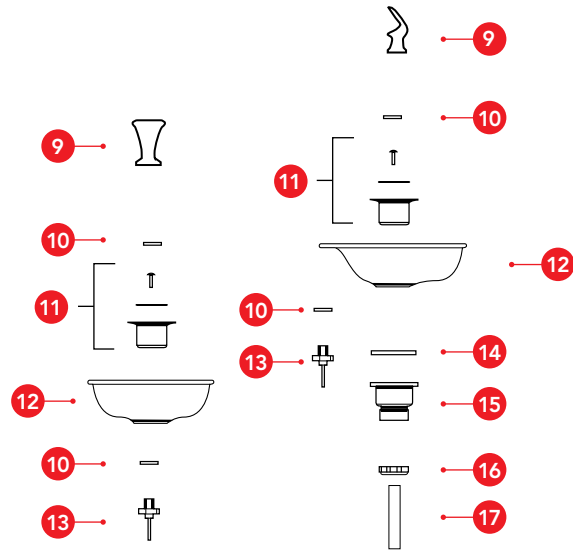

PARTS LIST

ITEM	PART	DESCRIPTION	ITEM	PART	DESCRIPTION
1	NA	Acorn Valve Assy.	14	100147140560	Drain Gasket
2*	NA	Dual Control Valve Assy.	15	55913C	Drain Fitting
3	NA	Rainbird Check Valve	16	55885C	Slip Joint Nut 1-1/4"
4	NA	Flow Control Fitting	17	66346C	Drain Tube
5	NA	Tube Assy.	18	45403C	FR Push Button Activator
6	50985C	Regulator Holder	19	55884C	Drain Elbow
7	61313C	Regulator	20	NA	Fitting 1-1/4" x 1-1/4"
8	NA	Regulator Nut	21	NA	Fitting- Double Male Connector
9	400942308640	Bubbler (Dual Stream)	22	NA	Pressure Fitting 1-1/4" x 3/4"
10	100322740560	Bubbler Gasket	23	NA	Drain Tube
11	600985551640	Drain Plug Assy.	24**	97482C	Dual Control Valve System Complete
12	170705042830	Basin Receptor			
13	15013C	Bubbler Tube Assy.			

* Includes items 1,3,4

** Includes items 1,3-8, 20-22

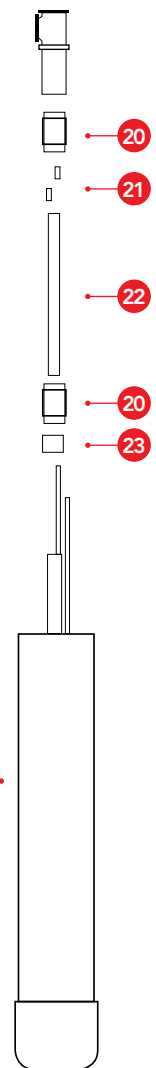

24